

Series 039 Air/Hydraulic Power Boosters

The De-Sta-Co Air/Hydraulic Power Booster converts normal shop-line air pressure to high-pressure hydraulic power. The six models available provide oil displacements ranging from 1 cu. in. to 12 cu. in. per stroke.

With the system filled, the volume of oil required to actuate a cylinder or pressure point is only equal to the cubic content of the piston displacement. The small booster, producing 1 cu. in. of usable oil per stroke, can operate 50 of the tiny 1/2-20 pressure points a full .22 max. stroke, and even more when strokes are kept to a minimum.

Features:

- Built-in manifold
- Complete automatic bleeding with each return stroke
- Automatic relief of system overcharge
- Automatic bleeding feature eliminates pre-filling
- Large volume visible oil reservoir automatically replenishes the system with reserve oil capacity
- Corrosion and wear-resistant materials
- Wear rings on hydraulic piston tube
- Unique self-centering air piston assures long life
- Increases hydraulic pressure to 3,000 PSIG from 100 PSIG air-line pressure
- All models supplied with SAE hydraulic ports
- NPT hydraulic ports available on request

039-104-000DE

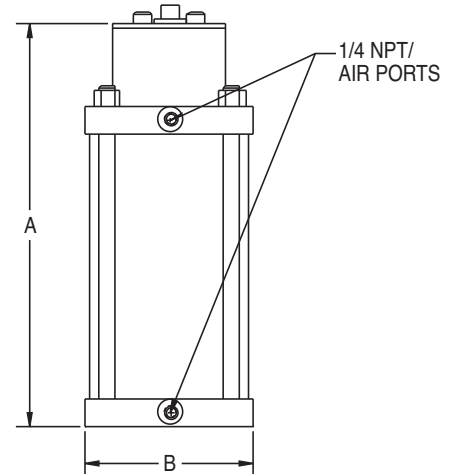
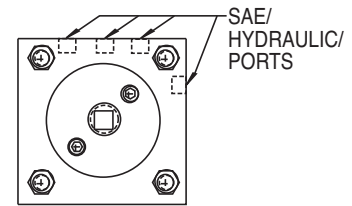
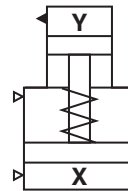

Model no.	Press Ratio	Displacement Per Stroke	Nominal Reservoir Capacity	Weight	Dimensions		Ports
					A	B (Square)	
039-101-000DE	33.87:1	1 cu. in.	10.4 cu. in.	9 lbs.	10.88	4.50	SAE #4
039-104-000DE	32.41:1	4 cu. in.	42 cu. in.	23 lbs.	16.38	6.50	SAE #4
039-108-000DE	30.97:1	8 cu. in.	96 cu. in.	43 lbs., 8 oz.	18.00	8.50	SAE #4
039-109-000DE	45.38:1	5 cu. in.	96 cu. in.	43 lbs.	18.00	8.50	SAE #4

(100 PSIG max. input air pressure)

Note: Special High Temperature Seals available for applications where Viton Seals are required. Order as H/T option.