

100279DE

Designed specifically for use with manual pallet valves, this *Single-Stage Pump* includes a 5 ft. hose and special female coupler (100908DE) to mate with our manual pallet valves.

Operation is simple: connect the coupler and release the pallet valve. Change the workpiece, then press the foot pedal to start the pump and clamp the piece. Rocking the pedal forward releases pressure in the coupler while the pallet valve maintains pressure at the pallet. At this point, the coupler and hose may be disconnected.

**Features:**

- Filtered filler/breather cap with dipstick
- 105 cu. in. metal reservoir
- SAE #6 outlet
- 1/4" NPTF air inlet port
- Shipped with hydraulic oil
- Foot treadle control allows "hands free" operation
- Operating Pressure Range (nominal):
  - 4,475 PSI max. @ 125 PSI air, max.
  - 1,150 PSI min. @ 40 PSI air, min.
- 98 cu. in. usable oil

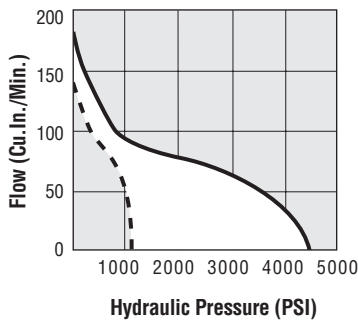

**Performance**

- No. 100279DE
- 125 psi Air Pressure
- - - 40 psi Air Pressure

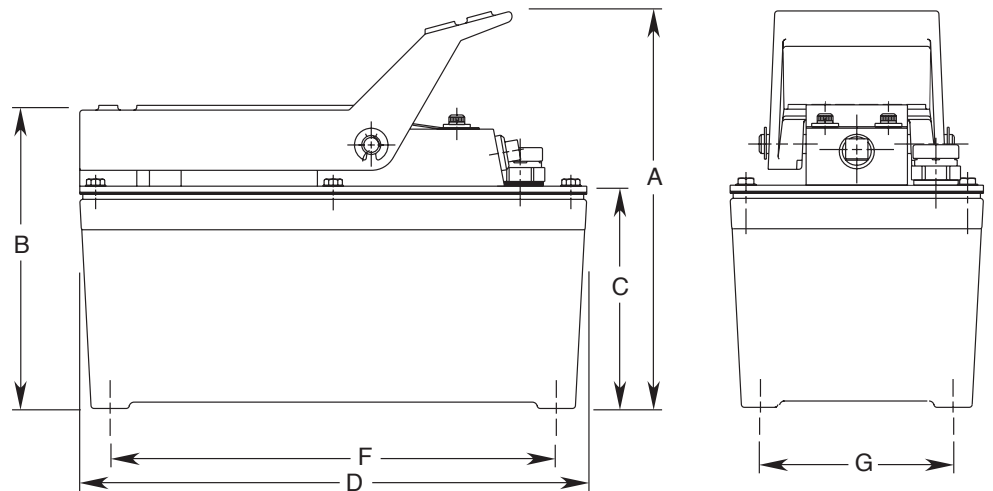
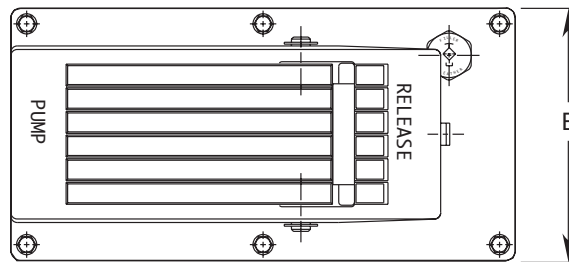

Model no.	Dimensions (In Inches)						
	A	B	C	D	E	F	G
100279DE	7.750	5.875	4.250	10.000	5.000	9.000	4.000

**NOTE:** This pump is not for use in normal "constant pressure" applications. Requires filtered, regulated, lubricated air supply. Air requirements: 20 CFM (max.) at low hydraulic pressure decreasing to 0 CFM when pump stalls.