



Robohand

DCT/CT Series Exploded View

DCT/CT SERIES
MAINTENANCE

2.45

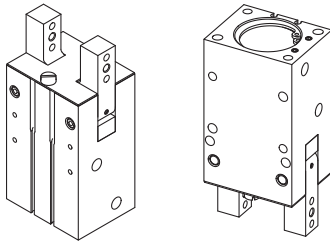

Item	Qty	Name
01	1	Body
02	1	Driver
03	1	Piston
04	2	Jaw
05	1	Washer
06	1	Cap
07	1	Shielded Plate
08	2	Wiper Cover
09	2	Drive Pin
10	2	Pivot Pin
54	1	Magnet

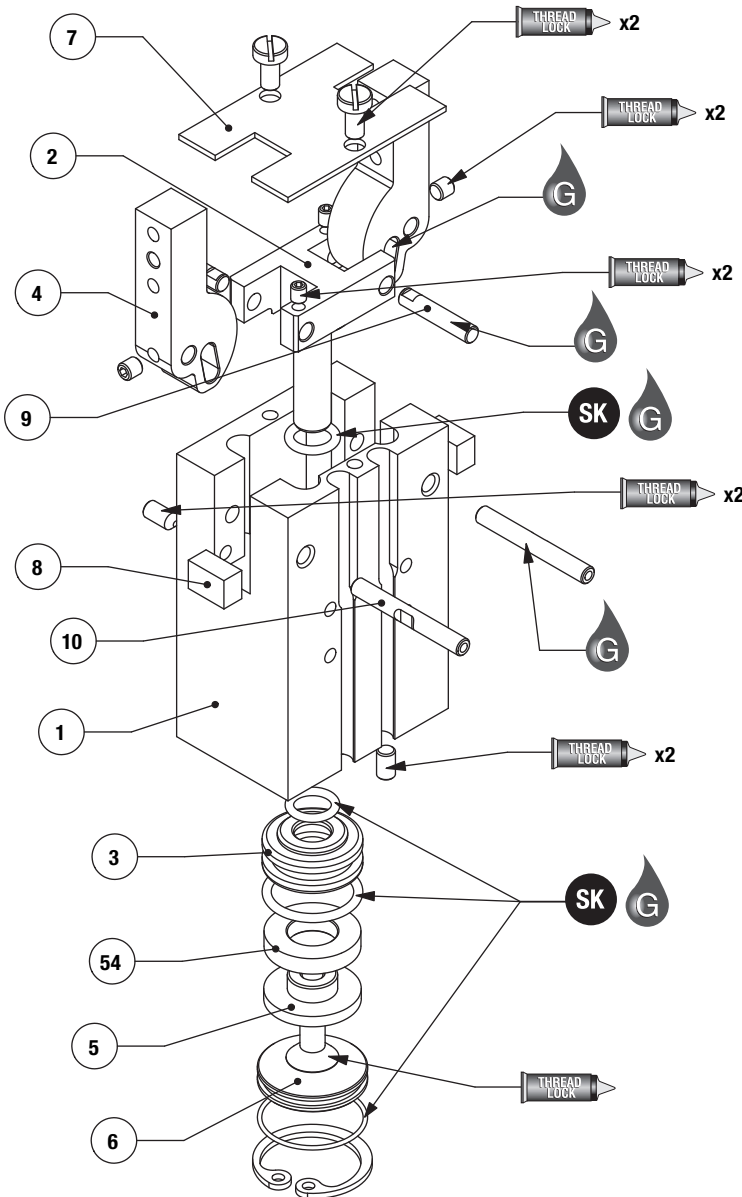

NOTE: Contact the Robohand Sales Department for a complete spare parts list with order numbers and prices.

Assembly Procedure

- Lubricate and install the seals into cap (x1), piston (x2) and body (x1)
- If top air ports are used, clear them and plug the side air ports on the body (#1)
- Lubricate the sloping rack of jaws (#4)
- Install both drive pins (#9) into driver (#2) through sloping racks of jaws. Check that the pin flat surface is correctly aligned before continuing with their installation.
- Lock drive pins in the driver with screws, tightening down on to the flat surface of the pins.
- Position driver and jaws assembly into body.
- Install both pivot pins (#10) into body, through the bore of jaws. Check that the pin flat surface is correctly aligned before continuing with their installation.
- Pivot pin locking:
 - DCT-12 (not shown): lock pivot pins into body with screws, tightening down on to the flat surface of the pins (pins are fixed into body and rotating into jaws)
 - DCT-16 to CT-50: lock pivot pins into jaws with screws, tightening down on to the flat surface of the pins (pins are fixed into jaws and rotating into body)
- Magnet mounting:
 - DCT-12 to DCT-20: install the magnet (#54) on the washer (#5)
 - DCT-25 to CT-50 (not shown): install magnet (#54) onto piston (#3) and lock it by means of its retaining ring.
- Piston mounting:
 - DCT-12 to DCT-20: insert the piston and the washer with magnet into body. Fix the assembly at the end of the driver with screw.
 - DCT-25 to CT-50 (not shown): insert the piston with magnet into body. Fix the assembly at the end of the drivers with screw.
- Check unit operation unladen.
- Install the cap (#6) into body and lock it by means of its retaining ring.
- Place both wiper covers (#8) into body and lock them with their screws.
- Fix the shielded plate (#7) onto body with both screws.

**SK Seal Repair Kit Order #'s
See Product Data Sheets**



Seal Kit Items



Thread Locker



Krytox™ Lubricant



Lightweight Machine Oil



Teflon® Based Grease



Super Bonder



Third Angle Projection

DCT/CT Series Assembled View

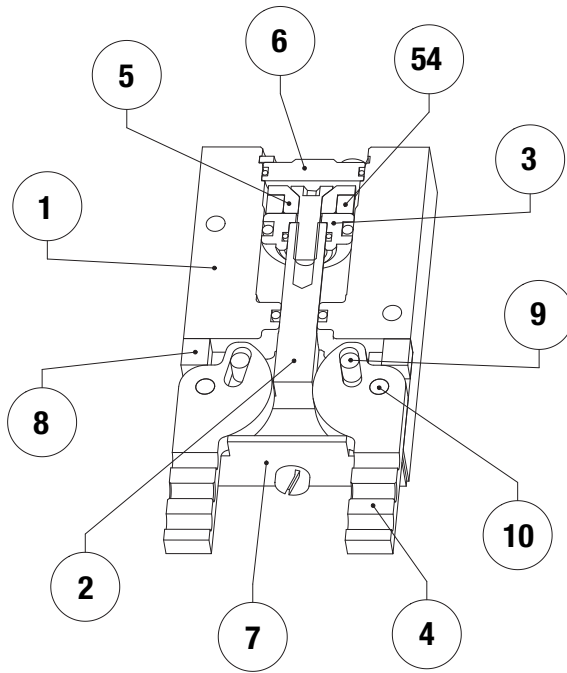
**DCT/CT SERIES
MAINTENANCE**
2.46

Item	Qty	Name
01	1	Body
02	1	Driver
03	1	Piston
04	2	Jaw
05	1	Washer
06	1	Cap
07	1	Shielded Plate
08	2	Wiper Cover
09	2	Drive Pin
10	2	Pivot Pin
54	1	Magnet

NOTE: Contact the Robohand Sales Department for a complete spare parts list with order numbers and prices.

Accessory Installation & Adjustment Instructions

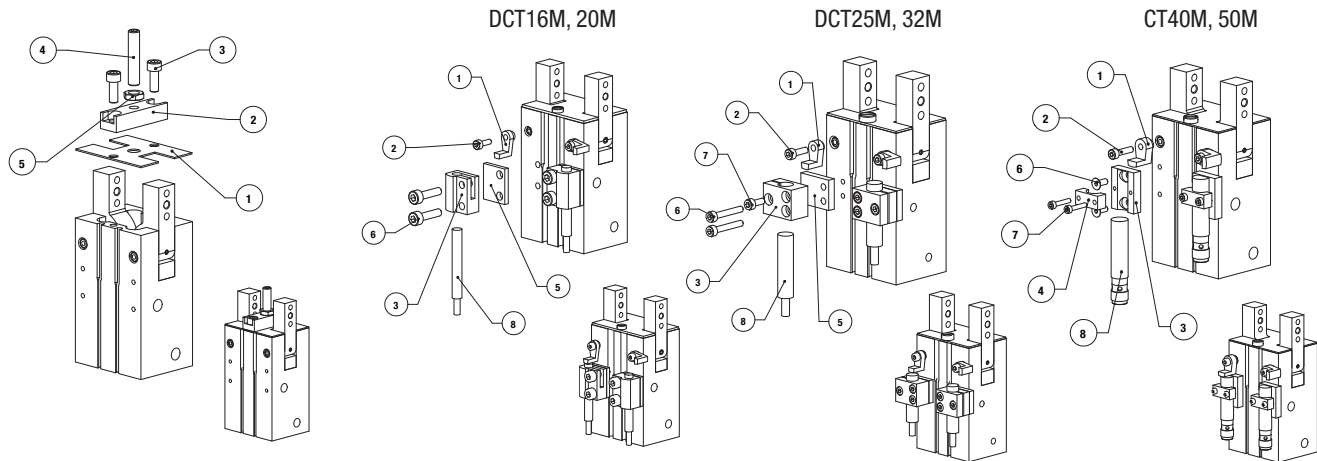

Installation - Adjustment Stop

- 1) Unscrew both screws for mounting of the shielded plate and remove it.
- 2) Fix the new shielded plate (#1) and the stop (#2) onto body with both screws (#3)
- 3) Install the locknut system (#4) and (#5) on the stop.
- 4) Tighten screw for maximum target jaw opening and lock with locknut.

Installation - Inductive Sensor Holders

- 1) Fix the flags (#1) at the end of pivot pins with their screws (#2)
- 2) Holder mounting:
 - DCT-16M to DCT-32M: fix holder (#3) and spacer (#5) onto body with both screws (#6)
 - DCT-40M to DCT-50M: fix holder (#3) onto body with both screws (#6)
- 3) Sensor mounting:
 - DCT-16M to DCT-20M: unscrew lightly both screws for mounting (#6) of holder and insert sensor (#8, not included) into it. Position sensor so that it senses up on flag. Lock the sensor by tightening both screws.
 - DCT-25M to DCT-32M: unscrew lightly screw (#7) on holder and insert sensor (#8, not included) into it. Position sensor so that it senses up the flag. Lock the sensor by tightening screw.
 - CT-40M to CT-50M: insert sensor (#8, not included) in stop into holder. Lock the sensor by tightening the collar holder with both screws (not shown).
- 4) Adjust flag position by unscrewing their screws for desired sensing positions.



Seal Kit Items



Thread Locker



Krytox™ Lubricant



Lightweight Machine Oil



Teflon® Based Grease



Super Bonder



Third Angle Projection