

# RR-56 & 66 Series Exploded View



Robohand

RR-56 & 66  
SERIES  
MAINTENANCE

3.48

## Item Qty Name

01	1	Body, Main
02	1	Flange
03	1	Pinion
04	2	Rack, Piston
05	1	Ring, Inner Bearing
06	1	Ring, Outer Bearing
07	1	End Plate
08	1	Ported End Plate
10	1	Washer, Thrust
11	2	Bearing, Thrust
13	1	Bearing, Needle
14	1	Bearing, Needle
16	1	Cap

**NOTE:** Contact the Robohand Sales Department for a complete spare parts list with order numbers and prices.

### Assembly Procedure

- 1) Lubricate and install seals
- 2) Place needle bearings, outer ring and spacers into body
- 3) Fasten inner ring to body..
- 4) Press radial bearing into underside of body.
- 5) Install racks into body.
- 6) Fasten outer ring to turntable/pinion assembly.
- 7) Fasten end plates and plugs.

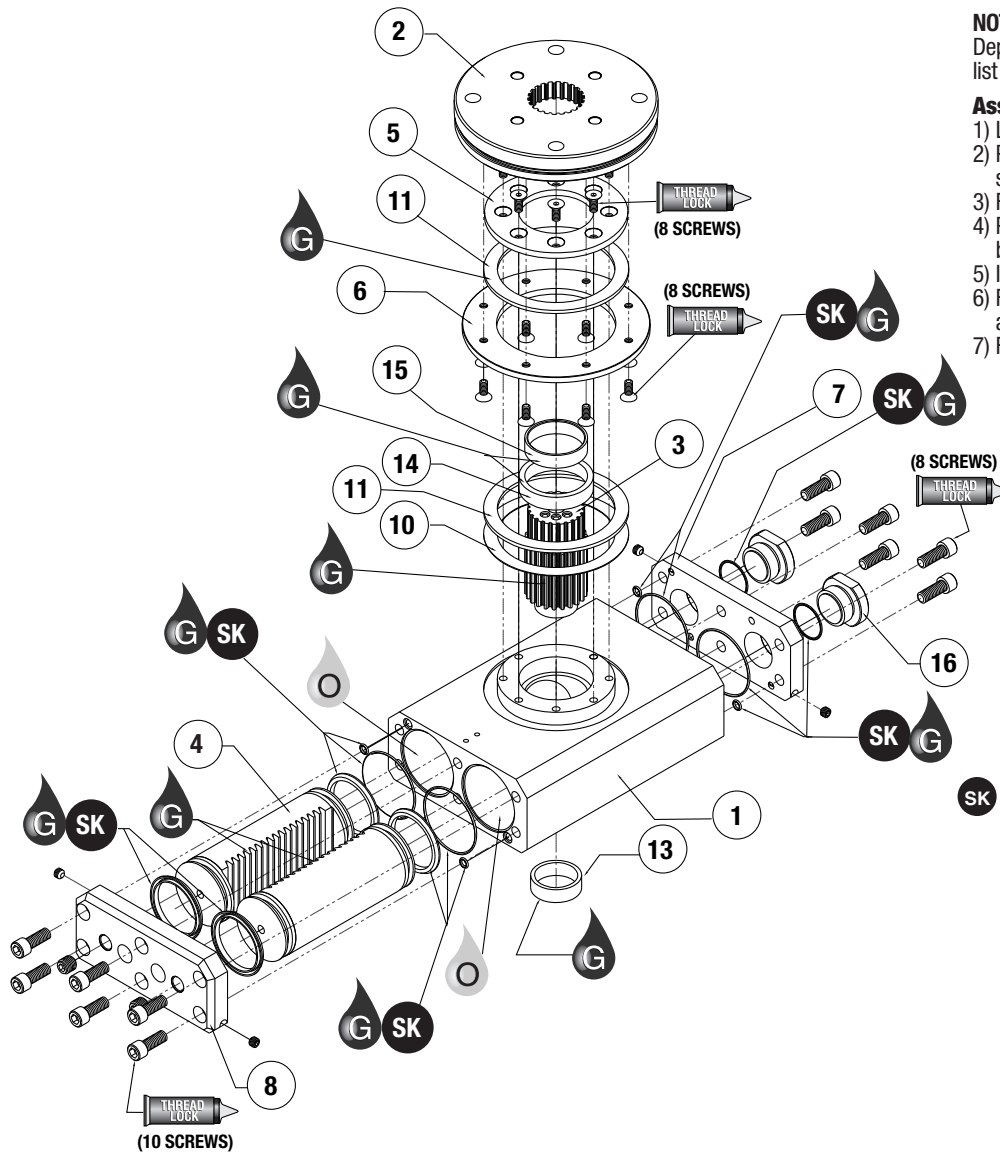

**SK Seal Repair Kit Order #'s  
See Product Data Sheets**



Seal Kit Items



Thread Locker



Krytox™ Lubricant



Lightweight Machine Oil



Teflon® Based Grease



Super Bonder



Third Angle Projection



Robohand

# RR-56 & 66 Series Assembled View

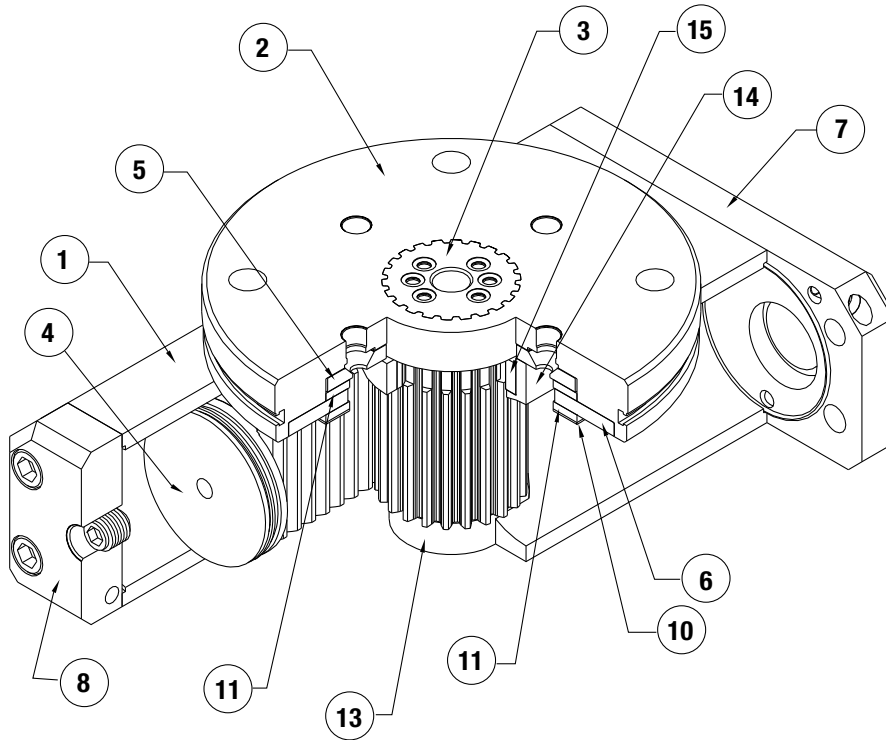

Item	Qty	Name
01	1	Body, Main
02	1	Flange
03	1	Pinion
04	2	Rack, Piston
05	1	Ring, Inner Bearing
06	1	Ring, Outer Bearing
07	1	End Plate
08	1	Ported End Plate
10	1	Washer, Thrust
11	2	Bearing, Thrust
13	1	Bearing, Needle
14	1	Bearing, Needle
16	1	Cap

**NOTE:** Contact the Robohand Sales Department for a complete spare parts list with order numbers and prices.

RR-56 & 66  
SERIES  
MAINTENANCE

3.49

## Accessory Installation & Adjustment Instructions

- 1) Install sensors and brackets as shown.
- 2) Install targets so when a turntable is at each end of stroke, a target is aligned with a sensor.

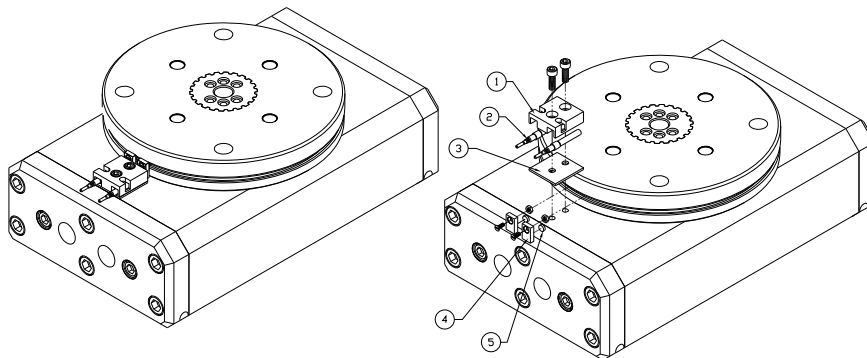

Seal Kit  
Items



Thread  
Locker



Krytox™  
Lubricant



Lightweight  
Machine Oil



Teflon® Based  
Grease



Super  
Bonder



Third Angle  
Projection

For more information call us at: **1.888.DESTACO** or **248.836.6700** Fax: **248.836.6901** Visit us on the Internet at: **www.destaco.com**

# RR-56 & 66 Options Exploded View



Robohand

RR-56 & 66  
OPTIONS  
MAINTENANCE  
3.50

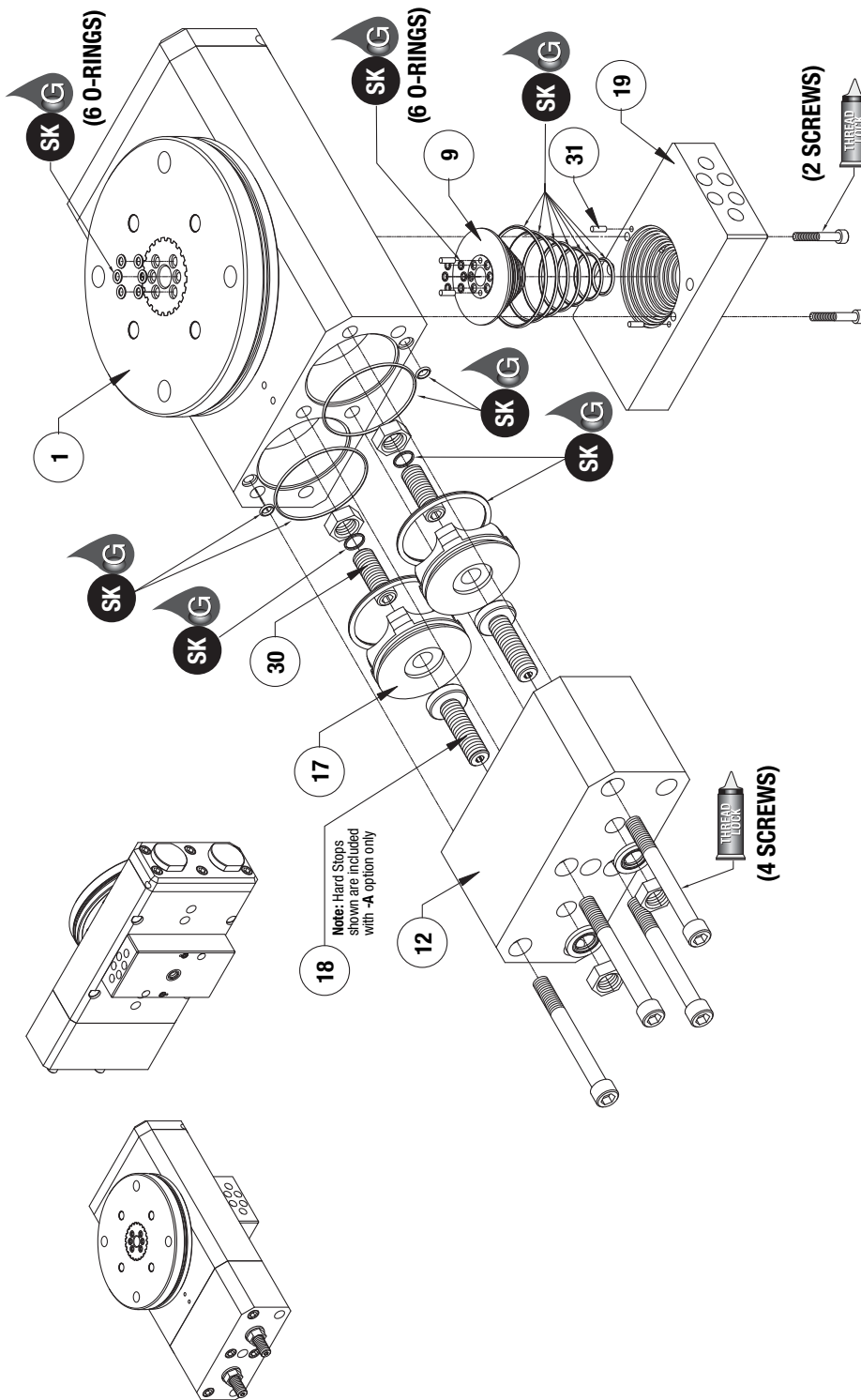

## Item Qty Name

### RR-56 & 66-S ( Midstop )

12	1	Body, Mid-Stop
17	2	Piston, Mid-Stop
30	2	Mid-Stop Adjustment Screws

### RR-56-M ( Rotary Manifold )

09	1	Manifold, Rotary
19	1	Manifold
31	4	Dowel Pin

**NOTE:** Contact the Robohand Sales Department for a complete spare parts list with order numbers and prices.

### Manifold Option Assembly Procedure

- 1) Lubricate and install 12 small o-rings. (6 in the pinion, 6 in the rotary manifold.)
- 2) Install 7 O-rings on the rotar y manifold.
- 3) Press 1/8" dia. dowel pin into manifold.
- 4) Install rotary manifold in manifold block.
- 5) Attach manifold block to rotary actuator body.

### Mid-Stop Option Assembly Procedure

- 1) Lubricate and install o-rings.
- 2) Install mid-stop pistons, adjustment screws, seal washers, and hex nuts in rotary actuator body.
- 3) Attach mid-stop body to rotary actuator body.
- 4) Install flow controls.

### Mid-Stop Adjustment Procedure

- 1) Remove mid-stop body from actuator base.
- 2) Remove the two mid-stop pistons from the mid-stop body and insert them into their respective cylinder bores in the actuator base.
- 3) Back off both mid-stop adjustment screws (#30) while pushing the mid-stop pistons firmly into the cylinder bores. the face of the pistons should seat against the actuator base. If not, then continue to back out the stop screws.
- 4) Turn the turntable to the desired position and advance the mid-stop adjustment screws until both screws touch the main piston faces.
- 5) Re-attach the two mid-stop pistons to the mid-stop body and fasten mid-stop body back onto actuator base.

**SK Seal Repair Kit Order #'s  
See Product Data Sheets**



Seal Kit Items



Thread Locker



Krytox™ Lubricant



Lightweight Machine Oil



Teflon® Based Grease



Super Bonder



Third Angle Projection



Robohand

# RR-56 & 66 Options Assembled View

### Item Qty Name

7	1	Plate, End
20	2	Shock Absorber

**NOTE:** Contact the Robohand Sales Department for a complete spare parts list with order numbers and prices.

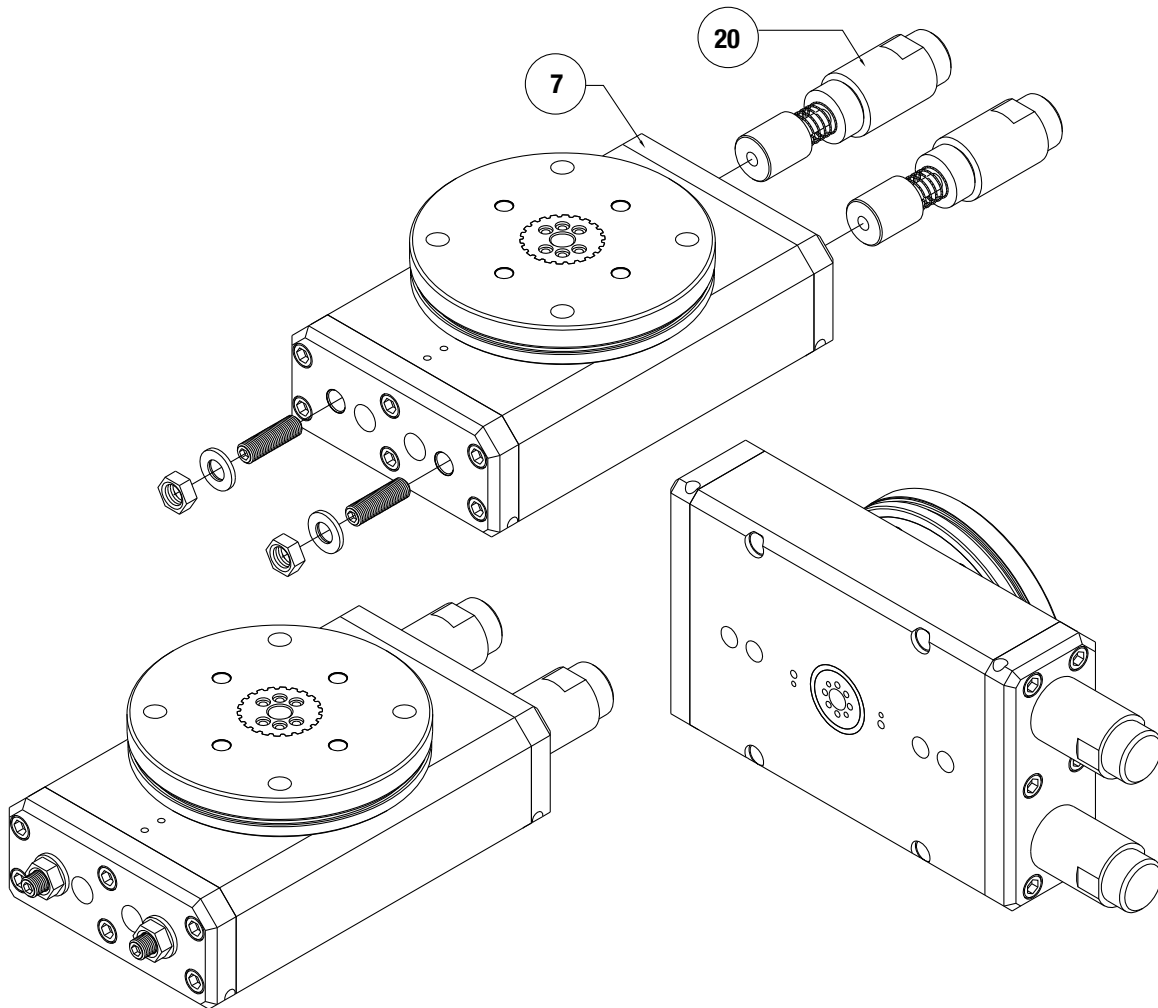

RR-56 & 66  
OPTIONS  
MAINTENANCE  
3.51



Seal Kit  
Items



Thread  
Locker



Krytox™  
Lubricant



Lightweight  
Machine Oil



Teflon® Based  
Grease



Super  
Bonder



Third Angle  
Projection